

SPECIFICATIONS DLF-530 Dry Lint Filter

The **DLF-530** model represent a efficient cyclone air flow design while providing large area filtration screens with minimal maintenance. This model is slimline and compact often referred to as “inline” or inside models. **System 500** models are all-weather construction and may be mounted outside.

BODY: The housing is made out of fire retardant laminating resin (Fiberglass). The unit comes with four 1-1/4” galvanized pipe legs for floor mounting.

FILTER: An inner stainless steel screen (50 mesh) is designed to filter 98% of lint passing through the chamber. The heavy duty screen should be reinforced with 1” webbing with quick change adjustable clamps.

LINT COLLECTION: Rotor Pipes form a frame joining top and bottom rotor assemblies. Pipes are made from 3/4” hard aluminum pipes. Provisions are made to adjust rotation speed of blowdown assembly. For maintenance, full rotor assembly may be entered and be assembled through inspection door. The inspection (access) door shall be hinged with quick release toggle clamps for easy access. This unit shall be equipped with a fire retardant vinyl holding bag for easy lint removal.

AUTO BLOWDOWN CONTROLS: (115-VAC) mechanical system is actuated by compressed air, which is controlled by a dryer cycle or an automatic repeatable electronic timer which activates a 3/4” compressed air solenoid valve.

EMERGENCY FIRE SUPPRESSION SYSTEM (Optional): Internally mounted overheat sensor energizes audio and visual alarm as well as opening a 3/4” solenoid valve connected with two 1/2” water sprinklers mounted on sides of filter body.

OVERPRESSURE ALARM (Optional): Overpressure in exhaust system is monitored by a differential switch, which activated an alarm and indicator lamp when pressure exceeds desired maximum setting on control.

INLET / OUTLET: Inlet: 50” X 50”, Horizontal Side Outlet: 27”H x 64”Wide.

INLET PLATE (Optional): Plate should made of 1/4” fiberglass with 3” slip stainless steel slip collar ring to accommodate the multiple ducts and facilitate proper air flow.

Capacity: 27,000 CFM without Booster Fan, 33,000 CFM with Booster Fan

Screen Area: 102 Sq. Ft.

Avg. Static Pressure: 0.25 WC

Screen Change Time: 15-30 min.

Blowdown Time: 10-15 sec

Compressed Air: 60 Gal @ 110 psi

Ship Wt: 1800 lbs., 2300 lbs. with fan

Electrical Req.: Filter 115V, 3 amp; Fan 208-240V or 440-480V/24or12A/50or60Hz

Shipping Cube: (1) 92”W x 92”L x 94”H and (1) 54”W x 54”L x 42”H (Fan)

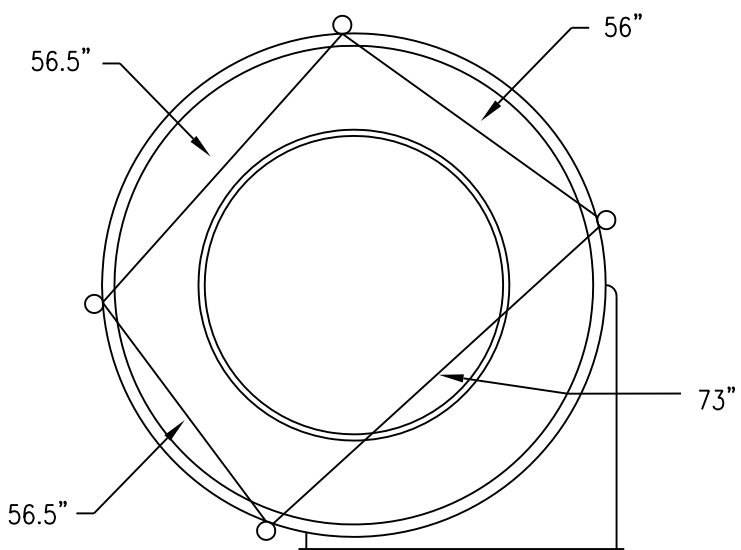
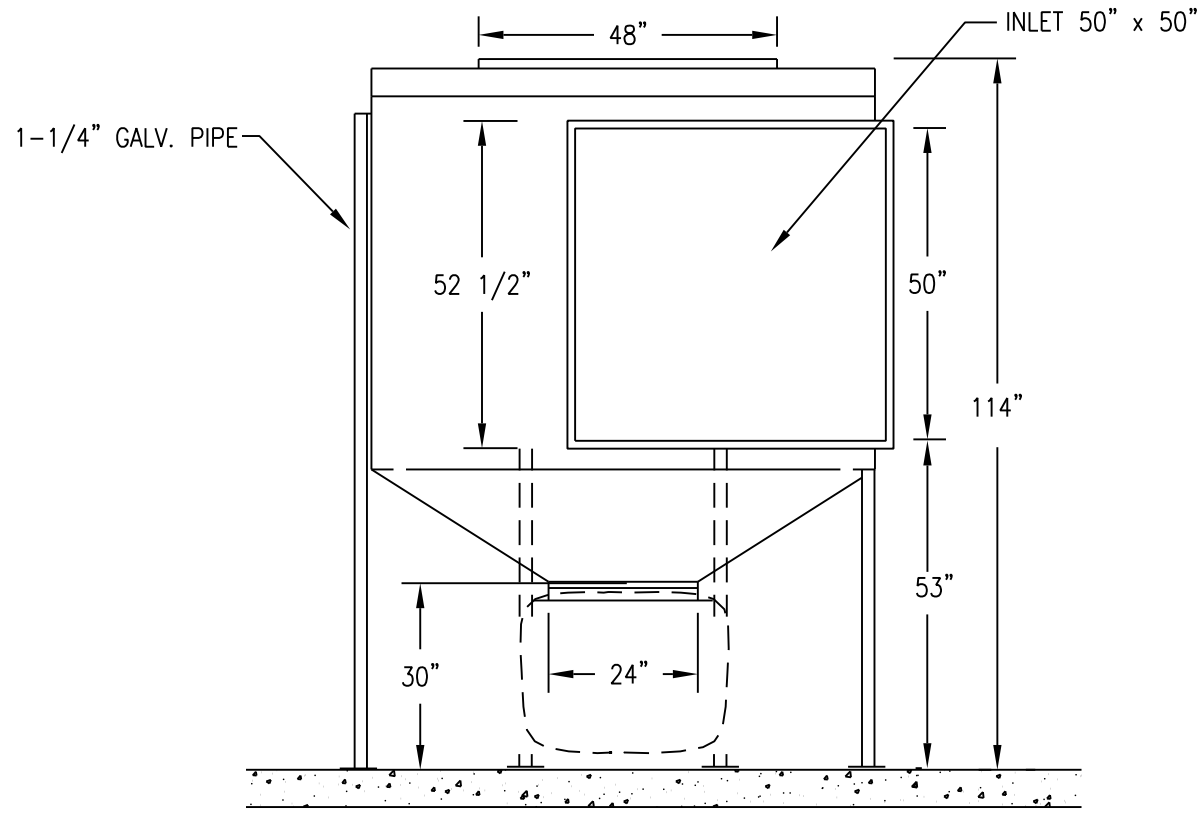
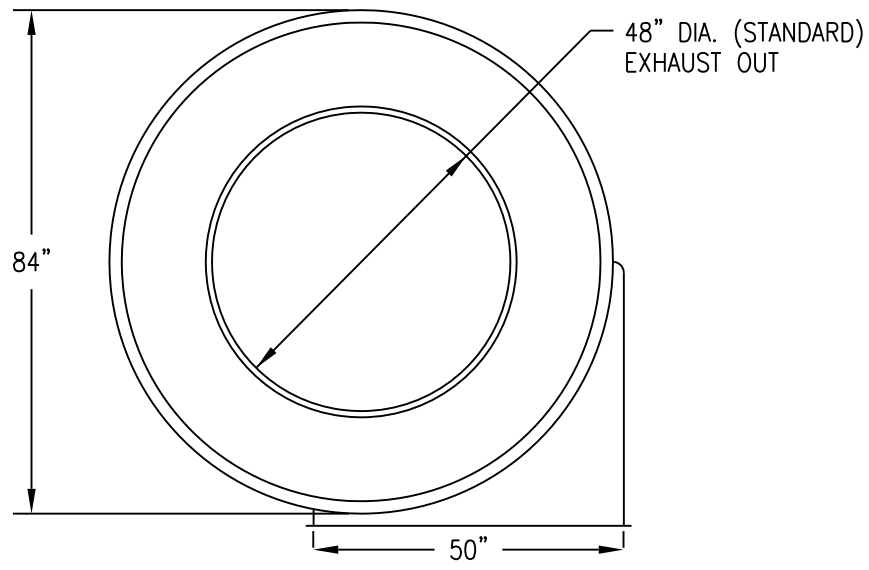

LINT FILTER-ASSEMBLY-INSTALLATION
MODEL DLF-530 30000 CFM

CLEAN CYCLE SYSTEMS
 A DIVISION OF TQ INDUSTRIES
 960 CROSSROADS BLVD., SEGUIN, TX 78155
 (830) 401-4400

DRAWN BY	MTR
SCALE	
DRAWING NO.	